



Dallas: Poltrona podologica per centro estetico

La poltrona Dallas è elettrica ed è ideale per diversi tipi di trattamenti estetici. E' dotata di regolazione della seduta in altezza, angolo della seduta e dello schienale grazie ad una pedaliera elettrica, inoltre ha due poggiatesta separati e indipendenti, regolabili manualmente. La poltrona è dotata anche di due braccioli completamente girevoli, per poterli utilizzare in tutte le posizioni, seduti e sdraiati. Il poggiatesta ed il poggiatesta sono regolabili in lunghezza ed altezza per un comfort totale del cliente.

ARTICOLI

MB/P10

MB/P11 poggiatesta singolo

MATERIALI

Struttura in legno multistrato imbottita con gommapiuma ad alto spessore rivestita in skai, fissata ad un telaio in metallo verniciato bianco lucido.

IN FOTO COLORE A: HOT CHOCOLATE 60 - B: MILK 61

Le immagini sono fornite al solo scopo illustrativo e non costituiscono elemento contrattuale

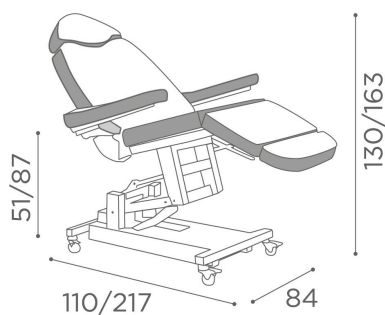

Colori: A B



Tutti i prodotti Medical&Beauty sono disponibili in una vasta scelta di colori senza costi aggiuntivi!



Tutti i prodotti Medical&Beauty sono disponibili in una vasta scelta di colori senza costi aggiuntivi!



black coffee 59



hot chocolate 60



milk 61



tea 62

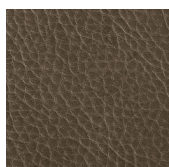

cappuccino 63

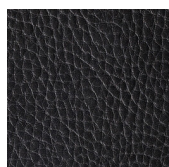

espresso 64



light grey G5



dark grey G6



olive G8 royal blue G9 marine L2 strawberry milk K4 vintage brown F5 vintage black G1 vintage tan G2 vintage white G3



vintage ash G4 vintage chocolate H9 vintage grey K1 vintage blue K2 vintage wine K7 vintage ice K8 black alligator 49 pebble black N1



slate grey N2 peacock blue N3 mulberry N4 cognac N5 sage green N6 black pearl P1



grey pearl P2 brown pearl P3 beige pearl P4 cognac pearl P5 green pearl P6 yellow pearl P7 red pearl P8 pink pearl P9



Via Lazzaretti 12 - 42122 - Reggio Emilia - Italy
Salon Ambience Italia - +39 0522 276740
International Sales - +39 0522 276755
Numero verde - 800 144552
Fax - +39 0522 276767
E-mail: info@salonambience.com

<https://www.facebook.com/salonambiencegroup>
<https://www.instagram.com/salonambiencegroup/>
https://www.youtube.com/channel/UCqTdWM-4_65Tr0Jul82kSCQ